

LAMPIRAN

Lampiran 1

KUESIONER PENELITIAN

PENGARUH *LIVE STREAMING* DAN HARGA DISKON TERHADAP MINAT BELI ULANG MELALUI KEPUASAN PELANGGAN PENGGUNA SHOPEE PRODUK SOMETHINC PADA MASYARAKAT KOTA MADIUN

Kepada Yth:

Bapak/Ibu/Saudara/i

Di Tempat

Sehubungan dengan pelaksanaan kegiatan penelitian saya dengan judul **“Pengaruh *Live Streaming* dan Harga Diskon Terhadap Minat Beli Ulang Melalui Kepuasan Pelanggan Pengguna Shopee Produk Somethinc Pada Masyarakat Kota Madiun”**, dengan ini saya:

Nama : Shinta Dwi Hartati

NIM : 2003102144

Prodi : Manajemen

Fakultas : Ekonomi dan Bisnis

Universitas : Universitas PGRI Madiun

Memohon kesediaan bapak/ibu/saudara/i pengguna *E-Commerce* Shopee yang melakukan pembelian produk somethinc untuk meluangkan waktunya guna melakukan pengisian kuesioner yang telah disediakan tanpa ada paksaan. Semua jawaban dan keterangan yang diperoleh akan dijaga kerahasiaannya dan hanya akan digunakan untuk keperluan penelitian. Saya mengucapkan terima kasih atas kerjasama dan partisipasi bapak/ibu/saudara/i, serta semua yang telah berkontribusi dalam mengisi kuesioner penelitian ini.

Hormat saya,

Shinta Dwi Hartati

IDENTITAS RESPONDEN:

Nama :

Jenis Kelamin :

- a. Laki-Laki
- b. Perempuan

Usia :

- a. 15-20 tahun
- b. 21-30 tahun
- c. 31-40 tahun
- d. 41-50 tahun

Pendidikan :

- a. SMA/SMK
- b. Diploma
- c. Sarjana
- d. Pascasarjana

Pekerjaan :

- a. Pelajar/Mahasiswa/i
- b. Karyawan
- c. Wirausaha
- d. TNI/Polri/PNS
- e. Lainnya.....

Penghasilan :

- a. <Rp 1.000.000
- b. Rp 1.000.000 - Rp 2.000.000
- c. Rp 2.000.000 – Rp 3.000.000
- d. >Rp 3.000.000

Domisili :

- a. Kecamatan Manguharjo
- b. Kecamatan Taman
- c. Kecamatan Kartoharjo

Berapa kali anda telah membeli produk Somethinc

- a. 1 – 2 kali
- b. 3 - 4 kali
- c. >5 kali

Petunjuk Pengisian silahkan anda pilih salah satu jawaban yang paling sesuai menurut anda dengan cara memberikan tanda pada tempat yang telah disediakan

Keterangan :

STS : Sangat Tidak Setuju nilainya 1

TS : Tidak Setuju nilainya 2

N : Netral nilainya 3

S : Setuju nilainya 4

SS : Sangat Setuju nilainya 5

No	Variabel dan Indikator	STS	TS	N	S	SS
Live Streaming (Chen et al, 2020) dalam (Islami, 2023)		1	2	3	4	5
Interaktif						
1.	Saya merasa tertarik membeli produk something melalui <i>live streaming</i> di <i>E-commerce</i> shopee karena <i>host live</i> melakukan <i>review</i> produk secara jelas					
2.	Saya lebih suka membeli produk something melalui <i>live streaming</i> di <i>E-commerce</i> shopee daripada <i>offline store</i>					
Kemudahan						
1.	Interaksi pada fitur shopee <i>live streaming</i> memudahkan pembeli untuk proses negosiasi					
2.	Saya lebih mudah memahami cara <i>checkout</i> produk something melalui <i>live streaming</i> di <i>E-commerce</i> shopee					
Efisiensi						
1.	Saya tertarik melakukan pembelian produk something melalui <i>live streaming</i> di <i>E-commerce</i> shopee karena bisa membeli dan membayar dalam satu waktu					
2.	Saya lebih suka membeli produk something melalui <i>live streaming</i> di <i>E-Commerce</i> shopee karena tidak perlu mengeluarkan banyak <i>effort</i>					
Fleksibilitas						
1.	<i>Live streaming</i> di <i>E-commerce</i> shopee memudahkan konsumen membeli produk something dimanapun dan kapanpun					
2.	Saya tetap bisa menonton dan membeli produk something di <i>E-commerce</i> shopee melalui <i>live streaming</i> sambil melakukan kegiatan lain					
Hiburan						

1.	Saya merasa terhibur dan tertarik melakukan pembelian produk something di <i>E-commerce</i> shopee melalui live streaming karena melihat <i>host me-review</i> dan memakai produk					
2.	Saya mencari hiburan di waktu luang dengan melakukan pembelian produk something melalui <i>live streaming</i> di <i>E-commerce</i> shopee					
Repeat Order						
1.	Setelah mengenal <i>live streaming</i> di <i>E-commerce</i> shopee, saya selalu membeli produk something melalui <i>live streaming</i>					
2.	Saya bersedia membeli ulang produk something melalui <i>live streaming</i> di <i>E-commerce</i> shopee					
Harga Diskon Sutisna (2012:300)		STS	TS	N	S	SS
Besarnya Potongan Harga						
1.	Saya senantiasa membeli produk something di <i>E-commerce</i> shopee, jika produk tersebut sedang menawarkan diskon					
2.	Saya tertarik melakukan pembelian produk something di <i>E-commerce</i> shopee jika mendapat diskon yang besar					
Masa Potongan Harga						
1.	Setiap melakukan pembelian produk something di <i>E-commerce</i> shopee, saya akan memeriksa lama waktu berlakunya diskon					
2.	Saya akan melakukan pembelian produk something di <i>E-commerce</i> shopee, jika masa berlakunya diskon akan segera berakhir					
Produk yang mendapatkan Potongan Harga						
1.	Saya tertarik membeli produk something di <i>E-commerce</i> shopee yang sedang diskon karena merasa lebih hemat					
2.	Saya merasa senang jika produk something di <i>E-commerce</i> shopee yang saya sukai sedang menawarkan diskon					
Kepuasan Pelanggan Indrasari (2019:92)		STS	TS	N	S	SS
Kesesuaian Harapan						
1.	Saya merasa puas karena <i>E-Commerce</i> shopee memiliki kesesuaian produk something dengan yang ditawarkan pada gambar					
2.	Saya merasa puas karena <i>E-commerce</i> shopee memiliki kesesuaian produk something yang dipesan dan diterima pelanggan					

Minat Berkunjung Kembali						
1.	Saya merasa puas membeli produk something di <i>E-commerce</i> shopee sehingga berminat mengunjungi kembali					
2.	Saya berminat mengunjungi kembali <i>E-Commerce</i> shopee untuk membeli produk something karena merasa puas					
Kesediaan Merekomendasikan						
1.	Saya merasa puas membeli produk something di <i>E-commerce</i> shopee, sehingga saya bersedia merekomendasikan kepada teman, keluarga atau orang lain untuk berlangganan					
2.	Produk something di <i>E-commerce</i> shopee, menjadi produk unggulan, sehingga untuk merekomendasikan kepada orang lain mudah untuk menjelaskannya					
Minat Beli Ulang Ali Hasan (2018)		STS	TS	N	S	SS
Minat Transaksional						
1.	Saya berminat membeli kembali produk something di <i>E-commerce</i> shopee					
2.	Produk something menyediakan beberapa varian yang memiliki fungsi berbeda sesuai kebutuhan wajah					
Minat Referensial						
1.	Saya bersedia merekomendasikan produk something di <i>E-commerce</i> shopee kepada orang terdekat					
2.	Saya bersedia merekomendasikan produk something di <i>E-commerce</i> shopee kepada orang lain					
Minat Preferensial						
1.	Saya berminat membeli produk something di <i>E-commerce</i> shopee karena dapat memenuhi kebutuhan perawatan wajah daripada produk lain					
2.	Perawatan wajah menggunakan produk something sangat memuaskan sehingga tidak akan beralih ke produk lain					
Minat Eksploratif						
1.	Saya bersedia menanyakan informasi produk something kepada orang yang sudah menggunakan					
2.	Saya bersedia mencari tahu pengalaman pengguna <i>E-commerce</i> shopee produk something melalui testimoni di media sosial					

Lampiran 2

Rekapitulasi Hasil Jawaban Responden

X₁ : *Live Streaming*

X₂ : *Harga Diskon*

Z : *Kepuasan Pelanggan*

Y : *Minat Beli Ulang*

X1.1	X1.2	X1.3	X1.4	X1.5	X1.6	X2.1	X2.2	X2.3	Z1	Z2	Z3	Y1	Y2	Y3	Y4
3	3	3	3,5	4	5	2	3,5	5	2,5	3,5	3,5	3,5	4	4	3
3	3	3	2,5	4	5	2	4	5	4	5	5	3,5	4	3,5	3,5
3	3	3	3	4	5	2,5	4,5	5	3,5	4,5	4,5	3,5	4	4	3,5
3	3	2,5	3	2,5	4	3	3,5	4	4,5	4,5	4,5	3,5	4	4	3,5
3	3	2,5	4	3	5	3	4	5	3	4	4	3,5	3,5	4	3,5
3	3	3	2,5	3,5	5	2,5	4	5	4	5	5	3,5	4	4	3,5
4	4	4	4	2,5	5	3	4,5	5	3,5	4,5	4,5	3,5	4	3,5	3,5
4	4	4	4	3	4	3,5	2,5	4	3,5	3,5	3,5	3,5	4	4	3,5
2,5	2,5	3,5	3	3	5	4	3,5	5	3	4	4	3,5	4	3,5	4
3	3	3	2,5	2,5	4	3,5	3,5	4	4	4	4	3,5	3,5	4	4
3,5	3,5	3,5	3,5	3	3,5	3	4,5	3,5	2,5	3,5	3,5	3,5	4	4,5	4
3	3	4	2,5	3	4,5	3,5	3	4,5	3	3	3	2,5	4	4,5	4,5
4	4	4	4	2	4,5	3,5	3,5	4,5	3,5	4,5	4,5	3,5	4,5	4,5	3,5
3,5	3,5	3,5	3	4	5	3,5	4	5	4,5	4,5	4,5	3,5	4,5	4	4,5
3,5	3,5	4	3	4,5	4,5	3,5	4	4,5	4	5	5	3,5	3	4,5	4
4	4	3	3	2	4	4,5	2,5	4	3,5	3,5	3,5	4,5	5	4,5	4,5
4	4	3	3	3	5	2,5	3,5	5	4	5	5	4	4,5	4,5	4
3	3	3,5	2,5	3	3,5	3,5	2,5	3,5	2,5	2,5	2,5	4,5	5	4,5	4,5
3,5	3,5	3,5	3	3,5	5	2,5	4,5	5	4	4	4	4	4,5	4,5	4
3	3	3	3	3,5	4,5	2,5	3	4,5	3,5	3,5	3,5	4,5	5	5	4,5
3,5	3,5	3,5	3	3	4,5	3,5	4	4,5	4	4	4	4	4	4,5	4
2,5	2,5	2	2,5	2	4	2,5	2	4	3	3	3	4,5	4,5	3,5	4
2	2	3,5	4	3	5	3	4	5	4,5	4,5	4,5	3,5	3,5	3,5	3
2,5	2,5	3	4	3,5	4,5	2	3	4,5	4,5	4,5	4,5	4	4,5	3,5	4
3	3	3,5	4,5	3,5	3,5	4	2	3,5	4	4	4	4	4	4	3
2,5	2,5	3	5	4	4	3	2,5	4	3	3	3	3	4	4	3
4	4	3	4	3,5	4	3,5	3	4	4	4	4	2	3,5	3,5	2,5
2,5	2,5	2	3	1,5	2	2	2,5	2	2	2	2	3	4	4	3
3	3	3	4,5	3	4	2	2,5	4	2,5	4	4	3,5	4	4	3
2	2	2,5	4,5	3	4,5	2,5	3,5	4,5	3,5	4,5	4,5	3,5	3	3	2
2,5	2,5	3,5	4,5	4	4	2,5	3	4	4	4	4	2,5	4	4	2,5
3	3	3	4	2,5	4	2,5	2,5	4	3	4	4	3	4	4	3
1,5	1,5	3,5	4,5	2,5	4,5	3	3,5	4,5	4	4,5	4,5	2	2	2	2,5

2	2	3	4	3,5	4	2,5	4	4	4	4	4	4	5	5	4
3,5	3,5	3	4	3,5	4	4	2,5	4	4	4	4	3,5	3	3	3,5
3	3	3,5	5	2	5	3	3,5	5	4,5	5	5	2,5	4,5	4,5	4
4	4	3,5	5	2,5	5	3	4	5	4,5	5	5	3	4,5	4,5	4
2,5	2,5	3,5	4	3,5	4	2,5	4	4	4	4	4	3	4	4	3,5
3	3	2,5	4,5	4,5	4,5	3,5	2,5	4,5	4,5	4,5	4,5	4	4,5	4,5	3,5
4	4	4	4,5	2,5	4,5	3,5	3,5	4,5	2,5	4,5	4,5	4,5	4,5	4,5	3
3	3	3,5	5	3,5	5	3,5	4	5	4	5	5	3	5	5	3,5
3,5	3,5	4,5	4,5	2	4,5	3,5	4,5	4,5	3,5	4,5	4,5	3	4	4	3
3	3	3,5	3	3	3	3	2	3	3	3	3	4	5	5	3,5
3,5	3,5	3	3	1,5	3	3	3	3	3	3	3	4,5	5	5	3
3,5	3,5	4,5	4,5	2	4,5	3,5	4	4,5	4,5	4,5	4,5	4,5	4,5	4,5	2,5
3	3	4	4,5	3,5	4	3,5	2,5	4	4	4	4	2,5	4	4	2,5
3	3	4,5	5	2,5	4,5	3,5	3	4,5	4,5	4,5	4,5	3	4	4	3
4	4	4	3,5	2	4	4	4	4	4	4	4	4	5	5	5
4	4	2	5	2	3,5	2,5	3	3,5	4,5	4,5	4,5	4	4	4	3,5
4	4	3	4	3,5	4,5	4,5	4,5	4,5	4	4	4	4,5	3,5	3,5	4
4	4	3	3,5	3,5	3,5	2,5	3	3,5	3,5	3,5	3,5	3	3,5	3,5	3,5
4,5	4,5	4	4	2	4	3,5	3	4	4	4	4	5	5	5	5
3,5	3,5	3	4	2	4	2,5	2,5	4	5	5	5	3	5	5	5
4,5	4,5	4,5	5	2	5	4	4	5	5	5	5	3	4	4	4
4	4	4	4,5	3	4,5	2,5	2,5	4,5	5	5	5	3,5	3	3	3
3,5	3,5	3,5	3	2	3	2,5	2,5	3	3	3	3	4,5	4	4	4
3,5	3,5	2,5	3,5	3	3,5	3	2,5	3,5	4	4	4	2,5	4	4	4
3	3	4	5	2	5	5	4,5	5	5	5	5	2,5	3	3	3
2	2	3	2	3	2	2	2	2	2	2	2	3,5	3,5	3,5	3,5
3,5	3,5	3,5	5	1	5	3,5	3,5	5	5	5	5	4,5	5	5	5
4	4	4	4	3	4	4	2,5	4	4	4	4	3	4,5	4,5	4,5
3,5	3,5	4,5	5	2,5	5	3,5	5	5	5	5	5	3	4,5	4,5	4,5
3	3	3	3	3,5	3	3	3,5	3	3	3	3	3,5	4,5	4,5	4,5
4	4	3,5	5	1,5	5	4	3,5	5	5	5	5	4,5	5	5	5
4	4	3	4	4	4	4	3	4	4	4	4	3	4	4	4
3	3	2,5	3	3,5	3	3	2	3	3	3	3	3	5	5	5
3	3	3	3	3	3	3	2,5	3	3	3	3	3,5	5	5	5
4	4	4	4	4	4	4	3,5	4	4	4	4	4	4,5	4,5	4,5
2	2	2	2	2	2	2	3	2	2	2	2	4	4	4	4
4	4	4	4	4	4	4	2,5	4	4	4	4	2,5	4	4	4
4	4	4	4	4	4	4	3	4	4	4	4	3,5	5	5	5
3,5	3,5	3,5	4,5	4,5	4,5	3,5	3,5	4,5	4,5	4,5	4,5	3	4	4	4
3	3	3	3	3	3	3	2	3	3	3	3	3,5	3,5	3,5	3,5
3	3	3	5	5	5	3	3,5	5	5	5	5	4	4,5	4,5	4,5

3	3	3	4	4	4	3	3,5	4	4	4	4	5	5	5	5
4	4	4	4	4	4	4	4	4	4	4	4	3	5	5	5
4	4	4	5	5	5	4	3	5	5	5	5	3	4	4	4
3,5	3,5	3,5	5	5	5	3,5	3,5	5	5	5	5	3	3	3	3
2,5	2,5	2,5	4	4	4	2,5	3,5	4	4	4	4	4	4	4	4
3,5	3,5	3,5	4,5	4,5	4,5	3,5	4	4,5	4,5	4,5	4,5	3	4,5	4,5	4,5
5	5	5	5	5	5	5	3	5	5	5	5	3,5	5	5	5
3,5	3,5	3,5	5	5	5	3,5	3,5	5	5	5	5	3,5	3,5	3,5	3,5
4	4	4	5	5	5	4	4	5	5	5	5	4,5	5	5	5
3	3	3	3	3	3	3	3,5	3	3	3	3	2	3,5	3,5	3,5
3,5	3,5	3,5	4,5	4,5	4,5	3,5	2,5	4,5	4,5	4,5	4,5	3,5	5	5	5
3	3	3	4	4	4	3	3	4	4	4	4	3,5	4	4	4
2	2	2	2	2	2	2	2,5	2	2	2	2	4	4,5	4,5	4,5
4,5	4,5	4,5	4,5	4,5	4,5	4,5	4,5	4,5	4,5	4,5	4,5	3	4	4	4
3,5	3,5	3,5	3,5	3,5	3,5	3,5	3,5	3,5	3,5	3,5	3,5	3	4,5	4,5	4,5
3,5	3,5	3,5	5	5	5	3,5	5	5	5	5	5	3	4,5	4,5	4,5
3	3	3	3,5	3,5	3,5	3	3,5	3,5	3,5	3,5	3,5	3,5	4,5	4,5	4,5
5	5	5	5	5	5	5	5	5	5	5	5	3,5	3,5	3,5	3,5
4	4	4	4	4	4	4	4	4	4	4	4	3	5	5	5
2,5	2,5	2,5	4	4	4	2,5	4	4	4	4	4	3,5	4,5	4,5	4,5
3	3	3	4	4	4	3	4	4	4	4	4	4	5	5	5
4	4	4	4	4	4	4	4	4	4	4	4	4,5	5	5	5
2	2	2	2	2	2	2	2	2	2	2	2	3	5	5	5
4	4	4	4	4	4	4	4	4	4	4	4	3	4,5	4,5	4,5
4	4	4	4	4	4	4	4	4	4	4	4	3,5	3,5	3,5	3,5
3	3	3	4,5	4,5	4,5	3	4,5	4,5	4,5	4,5	4,5	3,5	3,5	3,5	3,5
3,5	3,5	3,5	4,5	4,5	4,5	3,5	4,5	4,5	4,5	4,5	4,5	1	2	2	2
4	4	4	5	5	5	4	5	5	5	5	5	3	4	4	4
4	4	4	4	4	4	4	4	4	4	4	4	3,5	4	4	4
3,5	3,5	3,5	4,5	4,5	4,5	3,5	4,5	4,5	4,5	4,5	4,5	3,5	3,5	3,5	3,5
4	4	4	5	5	5	4	5	5	5	5	5	3	4	4	4
4,5	4,5	4,5	4,5	4,5	4,5	4,5	4,5	4,5	4,5	4,5	4,5	4	4	4	4
4	4	4	4	4	4	4	4	4	4	4	4	3	3	3	3
4	4	4	4	4	4	4	4	4	4	4	4	4	4	4	4
5	5	5	5	5	5	5	5	5	5	5	5	4	4	4	4
4,5	4,5	4,5	5	5	5	4,5	5	5	5	5	5	5	5	5	5
5	5	5	5	5	5	5	5	5	5	5	5	5	5	5	5
4,5	4,5	4,5	5	5	5	4,5	5	5	5	5	5	5	5	5	5
4	4	4	4	4	4	4	4	4	4	4	4	4,5	4,5	4,5	4,5
4,5	4,5	4,5	4,5	4,5	4,5	4,5	4,5	4,5	4,5	4,5	4,5	4	4	4	4
4	4	4	4	4	4	4	4	4	4	4	4	3	3	3	3

4,5	4,5	4,5	4,5	4,5	4,5	4,5	4,5	4,5	4,5	4,5	4,5	4	4	4	4	
3	3	3	3	3	3	3	3	3	3	3	3	4	4	4	4	
3,5	3,5	3,5	3,5	3,5	3,5	3,5	3,5	3,5	3,5	3,5	3,5	4	4	4	4	
4	4	4	4	4	4	4	4	4	4	4	4	3,5	3,5	3,5	3,5	
4	4	4	4	4	4	4	4	4	4	4	4	5	5	5	5	
5	5	5	5	5	5	5	5	5	5	5	5	4,5	4,5	4,5	4,5	
4,5	4,5	4,5	4,5	4,5	4,5	4,5	4,5	4,5	4,5	4,5	4,5	5	5	5	5	
5	5	5	5	5	5	5	5	5	5	5	5	4	4	4	4	
5	5	5	5	5	5	5	5	5	5	5	5	4,5	4,5	4,5	4,5	
3	3	3	3	3	3	3	3	3	3	3	3	3,5	2,5	3	3,5	
4	4	4	4	4	4	4	4	4	4	4	4	3,5	4,5	4,5	3,5	
5	5	5	5	5	5	5	5	5	5	5	5	4,5	4,5	4,5	4,5	
2	2	2	2	2	2	2	2	2	2	2	2	4,5	4,5	4,5	4,5	
5	5	5	5	5	5	5	5	5	5	5	5	3,5	3,5	3,5	3,5	
4	4	4	4	4	4	4	4	4	4	4	4	5	5	5	5	
5	5	5	5	5	5	5	5	5	5	5	5	2,5	4,5	4,5	2,5	
3	3	3	3	3	3	3	3	3	3	3	3	5	5	5	5	
5	5	5	5	5	5	5	5	5	5	5	5	3	3	3	3	
4	4	4	4	4	4	4	4	4	4	4	4	5	5	5	5	
4,5	4,5	4,5	4,5	4,5	4,5	4,5	4,5	4,5	4,5	4,5	4,5	4,5	4,5	4,5	4,5	
4,5	4,5	4,5	4,5	4,5	4,5	4,5	4,5	4,5	4,5	4,5	4,5	3,5	3,5	3,5	3,5	
3,5	3,5	3,5	3,5	3,5	3,5	3,5	3,5	3,5	3,5	3,5	3,5	3,5	3,5	3,5	3,5	
4,5	4,5	4,5	4,5	4,5	4,5	4,5	4,5	4,5	4,5	4,5	4,5	4	4	4	4	
3,5	3,5	3,5	3,5	3,5	3,5	3,5	3,5	3,5	3,5	3,5	3,5	4	4	4	4	
3,5	3,5	4,5	4,5	4	4	4,5	4	4	4	4	4	4	4	4	4	
3,5	3,5	4,5	4,5	5	5	4,5	4,5	5	4,5	4,5	4,5	4,5	4	4	4,5	
4	4	5	5	5	5	5	5	5	5	5	5	4	4	4	4	
3,5	3,5	3,5	3,5	4	4	3,5	4	4	4	4	4	4,5	4,5	4,5	4,5	
3,5	3,5	4	3,5	4	4	3,5	4	4	4	4	4	5	5	5	5	
4	4	5	5	5	5	5	5	5	5	5	5	4	4	4	4	
4,5	4,5	4,5	4,5	4,5	4,5	4,5	4,5	4,5	4,5	4,5	4,5	4,5	4,5	4,5	4,5	
4	4	5	5	5	5	5	5	5	5	5	5	4	4	4	4	
4,5	4,5	4,5	4,5	4,5	4,5	4,5	4,5	4,5	4,5	4,5	4,5	5	5	5	5	
3	3	5	5	5	5	5	5	5	5	5	5	5	5	5	5	
3,5	3,5	4,5	4,5	4,5	4,5	4,5	4,5	4,5	4,5	4,5	4,5	4,5	4,5	4,5	4,5	
3,5	3,5	3,5	3,5	4	4	3,5	3,5	4	4	4	4	4	4	4	4	
3	3	3	3	3	3	3	3	3	3	3	3	3	3	3	3	
3,5	3,5	4	5	4	4	4	3	4	3	3	3	3	3	3	3	
3,5	3,5	4	5	3	3	3	3	3	3	3	3	3	3	3	3	
3,5	3,5	3,5	3,5	2,5	2,5	2	2,5	2,5	2,5	2,5	2,5	2,5	2,5	2	3	2,5
3,5	3,5	3,5	3,5	3,5	3,5	3,5	3,5	3,5	3	3	3	4	4	3	4	

3	3	3	3	3	3	3	3	3	4	4	4	3	3	3	3
3,5	3,5	3,5	3,5	3,5	3,5	3,5	3,5	3,5	3	3	3	4	4	4	4
3	3	3	3	4	4	3	3	4	2,5	2,5	2,5	3	3	3	3
4	4	4	4	3	3	4	3,5	3	3	3	3	3	3	3	3
3,5	3,5	3,5	3,5	3,5	3,5	3,5	4	3,5	4	4	4	4	4	4	4
3,5	3,5	3,5	3,5	3,5	3,5	3,5	4	3,5	3	3	3	3,5	3,5	3	3,5
3	3	3	3	3	3	3	3	3	4	4	4	4	3,5	4	4
4	4	4	4	3,5	3,5	4	4	3,5	3,5	3,5	3,5	4,5	4	4	4,5
3	3	3	3	3	3	3	3	3	2,5	2,5	2,5	3	3	3	3
4	4	4	4	4	4	4	4	4	4	4	4	4	4	4	4
2,5	2,5	2,5	2,5	3	3	2,5	3	3	2,5	2,5	2,5	3	3	3	3
3	3	3	3	3	3	3	3	3	3	3	3	3	3	3	3
4	4	4	4	4	4	4	4	4	4	4	4	4	4	4	4
4	4	4	4	4	4	4	4	4	3	3	3	3	3	3	3
3	3	3	3	3	3	3	3	3	3	3	3	4	4	4	4
2,5	2,5	2,5	2,5	2	2	2,5	2	2	3,5	3,5	3,5	3,5	4	3	3,5
3	3	3	3	3	3	3	3	3	3	3	3	3	3	3	3
4	4	4	4	4	4	4	4	4	4	4	4	3	3	3	3
4	4	4	4	4	4	4	4	4	4	4	4	4	4	4	4
4	4	4	4	4	4	4	4	4	4	4	4	4	4	4	4
4	4	4	4	4	4	4	4	4	4	4	4	4	4	4	4
4	4	4	4	4	4	4	4	4	4	4	4	4	4	4	4
4	4	4	4	4	4	4	4	4	4	4	4	4	4	4	4
4	4	4	4	4	4	4	4	4	2,5	2,5	2,5	3	3	3	3
4	4	4	4	4	4	4	4	4	4	4	4	3	3,5	3	3
4	4	4	4	4	4	4	4	4	4	4	4	4	4	4	4
3	3	3	3	3	3	3	3	3	3	3	3	3	3	3	3
4	4	4	4	4	4	4	4	4	3,5	3,5	3,5	3	3,5	3	3
4	4	4	4	4	4	4	4	4	2,5	2,5	2,5	4	3,5	4	4
3,5	3,5	3,5	3,5	4	4	3,5	4	4	3	3	3	4	4	3	4
3	3	3	3	3	3	3	3	3	4	4	4	3	3	3	3
3,5	3,5	3,5	3,5	4	4	3,5	4	4	3	3	3	4	4	4	4
3	3	3	3	5	5	3	4	5	2,5	2,5	2,5	3	3	3	3
4	4	4	4	3,5	3,5	4	4	3,5	3	3	3	3	3	3	3
3,5	3,5	3,5	3,5	4	4	3,5	4	4	4	4	4	4	4	4	4
3,5	3,5	3,5	3,5	4	4	3,5	4	4	3	3	3	3,5	3,5	3	3,5
3	3	3	3	3	3	3	3	3	4	4	4	4	3,5	4	4
4	4	4	4	4	4	4	4	4	3,5	3,5	3,5	4,5	4	4	4,5
3	3	3	3	3	3	3	3	3	2,5	2,5	2,5	3	3	3	3
4	4	4	4	4	4	4	4	4	4	4	4	4	4	4	4
2,5	2,5	2,5	2,5	3	3	2,5	3	3	2,5	2,5	2,5	3	3	3	3
3	3	3	3	3	3	3	3	3	3	3	3	3	3	3	3

4	4	4	4	4	4	4	4	4	4	4	4	4	4	4	4
4	4	4	4	4	4	4	4	4	3	3	3	3	3	3	3
3	3	3	3	3	3	3	3	3	3	3	3	4	4	4	4
2,5	2,5	2,5	2,5	2	2	2,5	2	2	3,5	3,5	3,5	3,5	4	3	3,5
3	3	3	3	3	3	3	3	3	3	3	3	3	3	3	3
4	4	4	4	4	4	4	4	4	4	4	4	3	3	3	3
4	4	4	4	4	4	4	4	4	4	4	4	4	4	4	4
4	4	4	4	4	4	4	4	4	4	4	4	4	4	4	4
4	4	4	4	4	4	4	4	4	3	3	3	4	4	4	4
4	4	4	4	4	4	4	4	4	4	4	4	4	4	4	4
4	4	4	4	4	4	4	4	4	2,5	2,5	2,5	3	3	3	3
4	4	4	4	4	4	4	4	4	4	4	4	3	3,5	3	3
3	3	3	3	3	3	3	3	3	2,5	2,5	2,5	3	3	3	3
4	4	4	4	4	4	4	4	4	4	4	4	4	4	4	4
2,5	2,5	2,5	2,5	3	3	2,5	3	3	2,5	2,5	2,5	3	3	3	3
3	3	3	3	3	3	3	3	3	3	3	3	3	3	3	3
4	4	4	4	4	4	4	4	4	4	4	4	4	4	4	4
4	4	4	4	4	4	4	4	4	3	3	3	3	3	3	3
3	3	3	3	3	3	3	3	3	3	3	3	4	4	4	4
2,5	2,5	2,5	2,5	2	2	2,5	2	2	3,5	3,5	3,5	3,5	4	3	3,5
3	3	3	3	3	3	3	3	3	3	3	3	3	3	3	3
4	4	4	4	4	4	4	4	4	4	4	4	3	3	3	3
4	4	4	4	4	4	4	4	4	4	4	4	4	4	4	4
4	4	4	4	4	4	4	4	4	4	4	4	4	4	4	4
4	4	4	4	4	4	4	4	4	3	3	3	4	4	4	4
4	4	4	4	4	4	4	4	4	4	4	4	4	4	4	4
4	4	4	4	4	4	4	4	4	2,5	2,5	2,5	3	3	3	3
4	4	4	4	4	4	4	4	4	4	4	4	3	3,5	3	3
4	4	4	4	4	4	4	4	4	4	4	4	4	4	4	4
3	3	3	3	3	3	3	3	3	3	3	3	3	3	3	3
4	4	4	4	4	4	4	4	4	3,5	3,5	3,5	3	3,5	3	3
4	4	4	4	4	4	4	4	4	2,5	2,5	2,5	4	3,5	4	4
3,5	3,5	3,5	3,5	4	4	3,5	3,5	4	3	3	3	4	4	3	4
3	3	3	3	3	3	3	3	3	4	4	4	3	3	3	3
3,5	3,5	3,5	3,5	4	4	3,5	3,5	4	3	3	3	4	4	4	4
3	3	3	3	5	5	3	3	5	2,5	2,5	2,5	3	3	3	3
4	4	4	4	3,5	3,5	4	4	3,5	3	3	3	3	3	3	3
3,5	3,5	3,5	3,5	4	4	3,5	3,5	4	4	4	4	4	4	4	4
3,5	3,5	3,5	3,5	4	4	3,5	3,5	4	3	3	3	3,5	3,5	3	3,5
3	3	3	3	3	3	3	3	3	4	4	4	4	3,5	4	4
3	3	3	3	3	3	3	3	3	3	3	3	4	4	4	4

2,5	2,5	2,5	2,5	2	2	2,5	2,5	2	3,5	3,5	3,5	3,5	4	3	3,5
3	3	3	3	3	3	3	3	3	3	3	3	3	3	3	3
4	4	4	4	4	4	4	4	4	4	4	4	3	3	3	3
4	4	4	4	4	4	4	4	4	4	4	4	4	4	4	4
4	4	4	4	4	4	4	4	4	4	4	4	4	4	4	4
4	4	4	4	4	4	4	4	4	3	3	3	4	4	4	4
4	4	4	4	4	4	4	4	4	4	4	4	4	4	4	4
4	4	4	4	4	4	4	4	4	2,5	2,5	2,5	3	3	3	3
4	4	4	4	4	4	4	4	4	4	4	4	3	3,5	3	3
4	4	4	4	4	4	4	4	4	4	4	4	4	4	4	4
3	3	3	3	3	3	3	3	3	3	3	3	3	3	3	3
4	4	4	4	4	4	4	4	4	3,5	3,5	3,5	3	3,5	3	3
4	4	4	4	4	4	4	4	4	2,5	2,5	2,5	4	3,5	4	4
3,5	3,5	3,5	3,5	4	4	3,5	3,5	4	3	3	3	4	4	3	4
3	3	3	3	3	3	3	3	3	4	4	4	3	3	3	3
3,5	3,5	3,5	3,5	4	4	3,5	3,5	4	3	3	3	4	4	4	4
3	3	3	3	5	5	3	3	5	2,5	2,5	2,5	3	3	3	3
4	4	4	4	3,5	3,5	4	4	3,5	3	3	3	3	3	3	3
3,5	3,5	3,5	3,5	4	4	3,5	3,5	4	4	4	4	4	4	4	4
3,5	3,5	3,5	3,5	4	4	3,5	3,5	4	3	3	3	3,5	3,5	3	3,5
3	3	3	3	3	3	3	3	3	3,5	3,5	3,5	4	3,5	4	4
4	4	4	4	4	4	4	4	4	3,5	3,5	3,5	4,5	4	4	4,5
3	3	3	3	3	3	3	3	3	3	3	3	3	3	3	3
4	4	4	4	4	4	4	4	4	4	4	4	4	4	4	4
2,5	2,5	2,5	2,5	3	3	2,5	2,5	3	3	3	3	3	3	3	3
3	3	3	3	3	3	3	3	3	3	3	3	3	3	3	3
4	4	4	4	4	4	4	4	4	4	4	4	4	4	4	4
4	4	4	4	4	4	4	4	4	3	3	3	3	3	3	3
3	3	3	3	3	3	3	3	3	3	3	3	4	4	4	4
3	3	3	3	2,5	2,5	3	3	2,5	3,5	3,5	3,5	3,5	4	3	3,5
3	3	3	3	3	3	3	3	3	3	3	3	3	3	3	3
4	4	4	4	4	4	4	4	4	4	4	4	3	3	3	3
4	4	4	4	4	4	4	4	4	4	4	4	4	4	4	4
4	4	4	4	4	4	4	4	4	4	4	4	4	4	4	4
4	4	4	4	4	4	4	4	4	3	3	3	4	4	4	4
4	4	4	4	4	4	4	4	4	4	4	4	4	4	4	4
4	4	4	4	4	4	4	4	4	4	4	4	4	4	4	4
4	4	4	4	4	4	4	4	4	4	4	4	4	4	4	4
4	4	4	4	4	4	4	4	4	3	3	3	4	4	4	4
4	4	4	4	4	4	4	4	4	4	4	4	4	4	4	4
4	4	4	4	4	4	4	4	4	4	4	4	4	4	4	4
4	4	4	4	4	4	4	4	4	4	4	4	4	4	4	4
4	4	4	4	4	4	4	4	4	3	3	3	4	4	4	4
4	4	4	4	4	4	4	4	4	4	4	4	4	4	4	4
4	4	4	4	4	4	4	4	4	4	4	4	4	4	4	4

4	4	4	4	4	4	4	4	4	2,5	2,5	2,5	3	3	3	3
4	4	4	4	4	4	4	4	4	4	4	4	3	3,5	3	3
3	3	3	3	3	3	3	3	3	2,5	2,5	2,5	3	3	3	3
4	4	4	4	4	4	4	4	4	4	4	4	4	4	4	4
2,5	2,5	2,5	2,5	3	3	2,5	2,5	3	2,5	2,5	2,5	3	3	3	3
3	3	3	3	3	3	3	3	3	3	3	3	3	3	3	3
4	4	4	4	4	4	4	4	4	4	4	4	4	4	4	4
4	4	4	4	4	4	4	4	4	3	3	3	3	3	3	3
3	3	3	3	3	3	3	3	3	3	3	3	4	4	4	4
2,5	2,5	2,5	2,5	2	2	2,5	2,5	2	3,5	3,5	3,5	3,5	4	3	3,5
3	3	3	3	3	3	3	3	3	3	3	3	3	3	3	3
4	4	4	4	4	4	4	4	4	4	4	4	3	3	3	3
4	4	4	4	4	4	4	4	4	4	4	4	4	4	4	4
4	4	4	4	4	4	4	4	4	4	4	4	4	4	4	4
4	4	4	4	4	4	4	4	4	3	3	3	4	4	4	4
4	4	4	4	4	4	4	4	4	4	4	4	4	4	4	4
4	4	4	4	4	4	4	4	4	2,5	2,5	2,5	3	3	3	3
4	4	4	4	4	4	4	4	4	4	4	4	3	3,5	3	3
4	4	4	4	4	4	4	4	4	4	4	4	4	4	4	4
3	3	3	3	3	3	3	3	3	3	3	3	3	3	3	3
4	4	4	4	4	4	4	4	4	3,5	3,5	3,5	3	3,5	3	3
4	4	4	4	4	4	4	4	4	2,5	2,5	2,5	4	3,5	4	4
3,5	3,5	3,5	3,5	4	4	3,5	3,5	4	3	3	3	4	4	3	4
3	3	3	3	3	3	3	3	3	4	4	4	3	3	3	3
3,5	3,5	3,5	3,5	4	4	3,5	3,5	4	3	3	3	4	4	4	4
3	3	3	3	5	5	3	3	5	2,5	2,5	2,5	3	3	3	3
4	4	4	4	3,5	3,5	4	4	3,5	3	3	3	3	3	3	3
3,5	3,5	3,5	3,5	4	4	3,5	3,5	4	4	4	4	4	4	4	4
3,5	3,5	3,5	3,5	4	4	3,5	3,5	4	3	3	3	3,5	3,5	3	3,5
3	3	3	3	3	3	3	3	3	4	4	4	4	3,5	4	4
3	3	3	3	3	3	3	3	3	3	3	3	4	4	4	4
2,5	2,5	2,5	2,5	2	2	2,5	2,5	2	3,5	3,5	3,5	3,5	4	3	3,5
3	3	3	3	3	3	3	3	3	3	3	3	3	3	3	3
4	4	4	4	4	4	4	4	4	4	4	4	3	3	3	3
4	4	4	4	4	4	4	4	4	4	4	4	4	4	4	4
4	4	4	4	4	4	4	4	4	4	4	4	4	4	4	4
4	4	4	4	4	4	4	4	4	3	3	3	4	4	4	4
4	4	4	4	4	4	4	4	4	4	4	4	4	4	4	4
4	4	4	4	4	4	4	4	4	2,5	2,5	2,5	3	3	3	3
4	4	4	4	4	4	4	4	4	4	4	4	3	3,5	3	3
4	4	4	4	4	4	4	4	4	4	4	4	4	4	4	4

3	3	3	3	3	3	3	3	3	3	3	3	3	3	3	3
4	4	4	4	4	4	4	4	4	3,5	3,5	3,5	3	3,5	3	3
4	4	4	4	4	4	4	4	4	2,5	2,5	2,5	4	3,5	4	4
3,5	3,5	3,5	3,5	4	4	3,5	3,5	4	3	3	3	4	4	3	4
3	3	3	3	3	3	3	3	3	4	4	4	3	3	3	3
3,5	3,5	3,5	3,5	4	4	3,5	3,5	4	4	4	3	4	4	4	4
3	3	3	3	5	5	3	3	5	3	3	2,5	3	3	3	3
4	4	4	4	3,5	3,5	4	4	3,5	3	3	3	3	3	3	3
3,5	3,5	3,5	3,5	4	4	3,5	3,5	4	4	4	4	4	4	4	4
3,5	3,5	3,5	3,5	4	4	3,5	3,5	4	3,5	3,5	3	3,5	3,5	3	3,5
3	3	3	3	3	3	3	3	3	4	4	4	4	3,5	4	4
4	4	4	4	4	4	4	4	4	4,5	4,5	3,5	4,5	4	4	4,5
3	3	3	3	3	3	3	3	3	3	3	2,5	3	3	3	3
4	4	4	4	4	4	4	4	4	4	4	4	4	4	4	4
2	2,5	2,5	2,5	3	3	2,5	2,5	3	3	3	2,5	3	3	3	3
3,5	3	3	3	3	3	3	3	3	3	3	3	3	3	3	3
3,5	4	4	4	4	4	4	4	4	4	4	4	4	4	4	4
3	4	4	4	4	4	4	4	4	3	3	3	3	3	3	3
2,5	4	4	4	4	4	4	4	4	4	4	4	4	4	4	4
3,5	4	4	4	4	4	4	4	4	4	4	3	4	4	4	4
3	4	4	4	4	4	4	4	4	4	4	4	4	4	4	4
2,5	4	4	4	4	4	4	4	4	3	3	2,5	3	3	3	3
3,5	4	4	4	4	4	4	4	4	3	3	4	3	3,5	3	3
3	4	4	4	4	4	4	4	4	4	4	4	4	4	4	4
2	3	3	3	3	3	3	3	3	3	3	3	3	3	3	3
3,5	4	4	4	4	4	4	4	4	3	3	3,5	3	3,5	3	3
3	4	4	4	4	4	4	4	4	4	4	2,5	4	3,5	4	4
2	3,5	3,5	3,5	4	4	3,5	3,5	4	4	4	3	4	4	3	4
3	3	3	3	3	3	3	3	3	3	3	4	3	3	3	3
2,5	3,5	3,5	3,5	4	4	3,5	3,5	4	4	4	3	4	4	4	4
2	3	3	3	5	5	3	3	5	3	3	2,5	3	3	3	3
3,5	4	4	4	3,5	3,5	4	4	3,5	3	3	3	3	3	3	3
2,5	3,5	3	3,5	4	4	3,5	3,5	4	4	4	4	4	4	4	4
2	3,5	3	3,5	4	4	3,5	3,5	4	3,5	3,5	3	3,5	3,5	3	3,5
3,5	3	3	4	3	3	3	3	3	4	4	4	4	3,5	4	4
3,5	4	4	4	4	4	4	4	4	4,5	4,5	3,5	4,5	4	4	4,5
2,5	3	3	4	3	3	3	3	3	3	3,5	2,5	3	3	3	3
2,5	4	4	4	4	4	4	4	4	4	4	4	4	4	4	4
2	2,5	2,5	4	3	3	2,5	2,5	3	3	3,5	2,5	3	3	3	3
3,5	3	3	4	3	3	3	3	3	3	3,5	3	3	3	3	3
3,5	4	4	4	4	4	4	4	4	4	4	4	4	4	4	4

2,5	4	4	4	4	4	4	4	4	3	3,5	3	3	3	3	3
3	3	3	4	3	3	3	3	3	4	4	3	4	4	4	4
2,5	2,5	2,5	3,5	2	2	2,5	2,5	2	3,5	4,5	3,5	3,5	4	3	3,5
2	3	3	4	3	3	3	3	3	3	3,5	3	3	3	3	3
3,5	4	3	4	4	4	4	4	4	3	3,5	4	3	3	3	3
3	4	2	4,5	4	4	4	4	4	4	4,5	4	4	4	4	4
2,5	4	3	4	4	4	4	4	4	4	4,5	4	4	4	4	4
3,5	4	3	4	4	4	4	4	4	4,5	4,5	3	4	4	4	4
2,5	4	2	4	4	4	4	4	4	4,5	4,5	4	4	4	4	4
3	4	3	4	4	4	4	4	4	4	3,5	2,5	3	3	3	3
3	3	4	4	3	3	3	3	3	4	3,5	3	3	3	3	3
3	4	3	4,5	3,5	4	4	4	4	4	3,5	4	3	3	3	3
2,5	4	2,5	4,5	3	4	4	4	4	4,5	4,5	4	4	4	4	4
3	4	2,5	4,5	3	4	4	4	4	4	3,5	4	4	4	4	4
3,5	4	2,5	4	3	4	4	4	4	4	3,5	3	4	4	4	4
3,5	4	2,5	4	3,5	4	4	4	4	4	4	4	4	4	4	4
3,5	4	2,5	4	3	4	4	4	4	4	4	2,5	3	3	3	3
3,5	4	2,5	4	3	4	4	4	4	4	4	4	3	3,5	3	3
3,5	4	3	4,5	3	4	4	4	4	4,5	4	4	4	4	4	4
4	4	4	4	2,5	3	3	3	3	3	3,5	3	3	3	3	3
3,5	4	3,5	4,5	4	4	4	4	4	3	3,5	3,5	3	3,5	3	3
3,5	4	2	4,5	3	4	4	4	4	3	2,5	2,5	4	3,5	4	4
3	3,5	2	4,5	4	4	3,5	3,5	4	3	2,5	3	4	4	3	4

Lampiran 3

Uji Outer Model

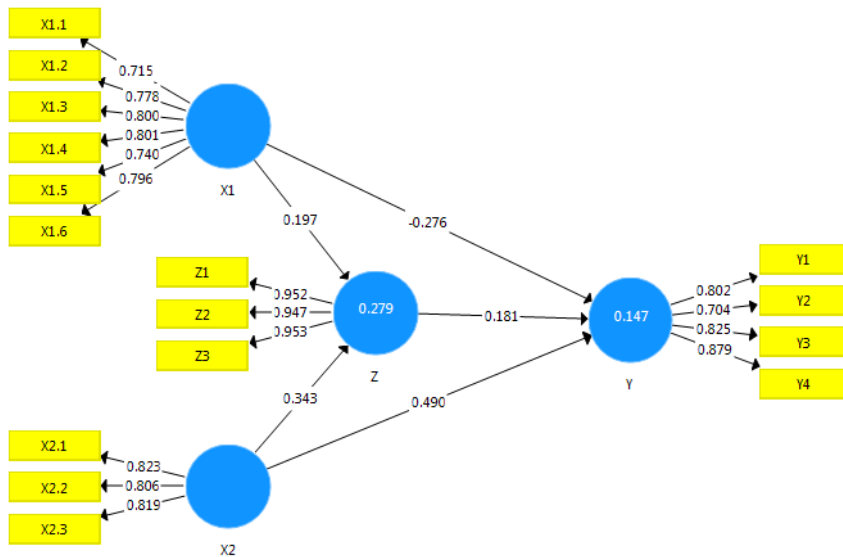

Lampiran 4

Inner Model

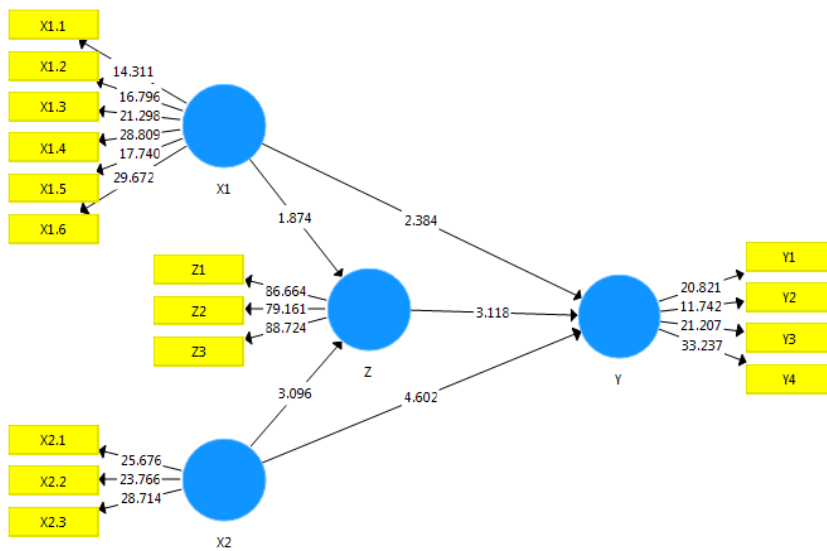

Lampiran 5

Uji Validitas

Outer Loading

	X1	X2	Y	Z
X1.1	0.715			
X1.2	0.778			
X1.3	0.800			
X1.4	0.801			
X1.5	0.740			
X1.6	0.796			
X2.1		0.823		
X2.2		0.806		
X2.3		0.819		
Y1			0.802	
Y2			0.704	

Outer Loading

	X1	X2	Y	Z
X1.6	0.796			
X2.1		0.823		
X2.2		0.806		
X2.3		0.819		
Y1			0.802	
Y2			0.704	
Y3			0.825	
Y4			0.879	
Z1				0.952
Z2				0.947
Z3				0.953

Lampiran 6

Uji Average Variant Extracted (AVE)

Validitas dan Reliabilitas Konstruk

Matriks	Cronbach's Alpha	rho_A	Reliabilitas Komposit	Rata-rata Varians Diekstrak ...	Salin ke Clipboard:	Format Excel	Format R
	Cronbach's Alpha	rho_A	Reliabilitas Ko...	Rata-rata Varians Diekstrak (AVE)			
X1	0.871	0.892	0.898	0.596			
X2	0.753	0.765	0.857	0.666			
Y	0.822	0.846	0.880	0.648			
Z	0.947	0.950	0.966	0.904			

Lampiran 7

Uji R Square

R Square

Matriks	R Square	Adjusted R Square	Salin ke Clipboard:	Format Excel	Format R
	R Square	Adjusted R Sq...			
Y	0.147	0.140			
Z	0.279	0.275			

Lampiran 8

Uji Q-Square

Redundansi Validasi-silang Konstruk

Total	Kasus1	Kasus2	Kasus3	Kasus4	Kasus5	Kasus6	Kasus7	Salin ke Clipboard:	Format Excel	Format R
		SSO	SSE	Q ² (=1-SSE/SSO)						
X1		2304.000	2304.000							
X2		1152.000	1152.000							
Y		1536.000	1404.219	0.086						
Z		1152.000	871.464	0.244						

Lampiran 9

Uji Model Fit

Model_Fit

Fit Summary	rms Theta	Copy to Clipboard:									Excel Format	R Format
		Saturated Model	Estimated Mo...									
SRMR		0.096	0.096									

Lampiran 10

Uji Hipotesis

Koefisien Jalur

Mean, STDEV, T-Values, P-Valu...	Keyakinan Interval	Keyakinan Interval Bias-Dikor...	Sampel	Salin ke Clipboard:			Format Excel	Format R
	Sampel Asli (O)	Rata-rata Sam...	Standar Devias...	T Statistik (O/...	P Values			
X1 -> Y	-0.276	-0.272	0.116	2.384	0.017			
X1 -> Z	0.197	0.205	0.105	1.874	0.062			
X2 -> Y	0.490	0.488	0.106	4.602	0.000			
X2 -> Z	0.343	0.333	0.111	3.096	0.002			
Z -> Y	0.181	0.187	0.058	3.118	0.002			

Lampiran 11

Uji Intervening

Efek Tidak Langsung Spesifik

	Mean, STDEV, T-Values, P-Valu...	Keyakinan Interval	Keyakinan Interval Bias-Dikor...	Sampel	Salin ke Clipboard:	Format Excel	Format R
	Sampel Asli (O)	Rata-rata Sam...	Standar Devias...	T Statistik (O/...	P Values		
X1 -> Z -> Y	0.036	0.038	0.024	1.512	0.131		
X2 -> Z -> Y	0.062	0.062	0.028	2.233	0.026		

VALIDASI SUMBER PUSTAKA PENULISAN SKRIPSI

Nama : Shinta Dwi Hartati
 Nim : 2003102144
 Program Studi : Manajemen
 Fakultas : Ekonomi dan Bisnis
 Dosen Pembimbing I : Dr. Heny Sidanti, S.E., M.M
 Dosen Pembimbing II : Dr. Apriyanti, S.E., M.M
 Judul : Pengaruh *Live Streaming* dan Harga Diskon Terhadap Minat Beli Ulang Melalui Kepuasan Pelanggan Pengguna Shopee Produk Somethinc Pada Masyarakat Kota Madiun

No.	Sumber Pustaka	Halaman		Hasil Validasi	
		Pustaka	Skripsi	Sesuai	Tidak Sesuai
1.	Amalia, P. (2023). Pengaruh Diskon Tanggal Kembar Dan Gratis Ongkir Shopee Terhadap Perilaku Konsumtif Mahasiswa Ekonomi Islam Uii. (<i>Doctoral Dissertation, Universitas Islam Indonesia</i>).	20	22	✓	
2.	Apriyani, N., & Suharti. (2016). Nuri Apriani & Suharti / Jurnal Manajemen Dewantara 1 (1): 21 - 34. <i>Jurnal Manajemen Dewantara, 1(1), 21-34.</i>	24	15	✓	
3.	Astuti, A. F. W., & Sidanti, H. (2022). Pengaruh Customer Satisfaction, Brand Image dan Brand Trust terhadap Repurchase Intention Batik Pecel di Kota Madiun (Studi Kasus Konsumen Batik Murni di Kota Madiun). <i>SIMBA: Seminar Inovasi Manajemen, Bisnis, Dan Akuntansi, 5</i> . https://prosiding.unipma.ac.id/index.php/SIMBA/article/view/4886	3	24	✓	
4.	Asriyati. 2020. "pengaruh word of mouth marketing (wom) terhadap kepuasan konsumen dengan keputusan pembelian	56	86	✓	

	sebagai variabel pemediasi (studi kasus warung bakso & soto sami asih pak birin purwokerto).”				
5.	Atfin, R. A. (2017). <i>Pengaruh Kualitas Produk Potongan Harga dan Promosi Melalui Instagram Terhadap Minat Membeli Ulang Pada Distro Three Second Jember.</i>	66	6, 27, 38, 91	✓	
6.	Budiyanto, E. (2018). Pengaruh Persepsi Harga, Diskon Harga, Dan Kualitas Pelayanan Terhadap Kepuasan Konsumen Pada Giant Supermarket Rungkut Surabaya. <i>Ekonomi</i> , 03(01), 36-46.	45	28, 36, 88,	✓	
7.	Chen, Y., Lu, F., & Zheng, S. (2020). A Study on the Influence of E-Commerce Live Streaming on Consumer Repurchase Intentions. <i>International Journal of Marketing Studies</i> , 12(4), 48. https://doi.org/10.5539/ijms.v12n4p48	59	5, 28, 34, 37, 89,	✓	
8.	Christono, A. B. (2022). Pengaruh Kualitas Pelayanan dan Harga terhadap Kepuasan Pelanggan. <i>Journal of Economics and Business UBS</i> , 8(1), 1-17. https://doi.org/10.52644/joeb.v8i1.13	114	25	✓	
9.	Christy, S. A. (2023). Pengaruh Kualitas Produk, Peran Influencer, Dan Fitur Live Streaming Sebagai Digital Marketing Terhadap Keputusan Pembelian Produk Fashion Melalui Aplikasi Tiktok. <i>Prosiding: Ekonomi Dan Bisnis</i> , 3(1), 4.	26	18	✓	
10.	Fathurrohman, D., Nurlenawati, N., & Triadinda, D. (2023). Pengaruh Live Streaming dan Customer Rating terhadap Keputusan Pembelian Hijab Kenan di Tiktok. <i>Management Studies and Entrepreneurship Journal</i> , 4(5), 6320-6334. http://journal.yrpiiku.com/index.php/msej	6322	17	✓	
11.	Ghozali, I. (2015). <i>Partiel Least Squares Konsep, Teknik dan Aplikasi Menggunakan Program Smart PLS 2.0 M3</i> . Semarang: Badan Penerbit Universitas Diponegoro.	7, 13, 22, 25	53, 54, 55, 57, 58	✓	
12.	Ghozali, I. (2016). <i>Aplikasi Analisis Multivariate Dengan Program IBM</i>	8	52	✓	

	SPSS 21, Edisi 8. Semarang: Badan Penerbit Universitas Diponegoro.				
13.	Harita, H. T. S., & Siregar, O. M. (2022). PENGARUH DIRECT MARKETING DAN PRODUCT QUALITY MINAT BELI ULANG PADA LIVE STREAMING MARKETING TIKTOK (Studi pada pengguna aplikasi Tiktok di Kota Medan). <i>Jurnal Ekonomi Kreatif Dan Manajemen Bisnis Digital, Volume 1(2)</i> , 171–184.	173	37	✓	
14.	Hermawan, A. (2012). <i>Komunikasi pemasaran</i> . Erlangga.	133	21	✓	
15.	Imran, M. I. A. (2018). Pengaruh Kepuasan Pelanggan Terhadap Minat Beli Ulang makanan di rumah makan ayam bakar wong solo alauddin kota makassar. <i>Jurnal Profitability Fakultas Ekonomi Dan Bisnis, 2(1)</i> , 50–64.	1	28, 39, 92	✓	
16.	Indrasari, M. (2019). <i>Pemasaran dan Kepuasan Pelanggan: Pemasaran dan Kepuasan Pelanggan</i> . unitomo press.	87-88	36	✓	
17.	Indriani, D. (2018). <i>Perilaku Konsumen di Masa Bisnis Online</i> . ANDI.	71	35	✓	
18.	Isfantin, S., & Lestari, P. (2018). Pengaruh Price Discount dan Bonus Pack terhadap Impulse Buying melalui Nilai Hedonik di Carrefour Surakarta. 7(2), 129–140. https://doi.org/10.30588/jmp.v7i2.362	132	21, 22	✓	
19.	Islami, C. D. (2023). PENGARUH LIVE STREAMING, KUALITAS PRODUK, DAN CITRA MEREK TERHADAP KEPUTUSAN PEMBELIAN PADA TOKO ONLINE EFABRIC. 1–110. https://eskripsi.usm.ac.id/files/skripsi/B11A/2020/B.131.20.0043/B.131.20.0043-15-File-Komplit-20240105095946.pdf	17	19	✓	
20.	Kotler, P. (2016). <i>Marketing for Competitiveness</i> . Bentang Pustaka.	84	20	✓	
21.	Kotler, P dan Keller, K. 2009. <i>Manajemen Pemasaran Jilid 1 Edisi ke 13</i> . Bandung: Erlangga.	139	7	✓	
22.	Kotler, P., & Keller, K. L. (2016). <i>Marketing Management (15th ed.)</i> . Pearson	84,	15, 20, 49	✓	

	Education Limited.				
23.	Lupita, P. (2013). Pengaruh Harga Diskon Dan Kualitas Produk Terhadap Minat Pembelian Ulang Pada Produk Fashion (Inditex) Di PT Mitra Adiperkasa, Tbk. <i>Jurnal Ilmiah Universitas Bakrie</i> , 1-2.	1	6, 27, 38, 91	✓	
24.	Marlina, H., Rizan, M., Ferry Wibowo, S., & Author, C. (2024). The Influence of Live streaming, E-Promotions and Content Marketing on Repurchase Intentions with Customer Satisfaction as an Intervening Variable (Case Study on Local Brand Jiniso). <i>International Journal of Economics, Management and Accounting (IJEMA)</i> , 1(8), 2988-7615.	616-617	5, 33, 34, 35, 37, 40, 89, 94	✓	
25.	Mausul, D. C., & Ma'mun, S. M. (2024). Pengaruh Live Streaming Tiktok Shop (Studi Minat Pembelian Pengguna Live Streaming di Akun Media Sosial TikTok @imazanhijab). <i>Karimah Tauhid</i> , 3(2), 2391-2400.	2392-2393	35	✓	
26.	Mirandi, O. A. S., & Rimiyati, H. (2023). Pengaruh Diskon, Kualitas Produk, Dan Citra Merek Terhadap Minat Pembelian Ulang Dengan Kepuasan Pelanggan Sebagai Variabel Intervening Pada Matahari Department Store Yogyakarta. <i>Journal of Business and Halal Industry</i> , 1(2), 1-10. https://doi.org/10.47134/jbhi.v1i2.106	7-8	6, 33, 34, 35, 38, 39, 91, 92	✓	
27.	Nuraini, S. (2023). <i>PENGARUH LIVE STREAMING, BRAND AWARENESS, DAN BRAND IMAGE TERHADAP KEPUASAN PELANGGAN PRODUK HENZ ABC DI PT TIRTA GRACIA UTAMA</i> . Universitas GICI.	1	32, 35, 87	✓	
28.	Nurdiansah, A., & Widyastuti, W. (2022). Pengaruh Price Discount Terhadap Customer Satisfaction Dan Repurchase Intention (Studi Pada Pengguna Shopee Food). <i>SIBATIK JOURNAL: Jurnal Ilmiah Bidang Sosial, Ekonomi, Budaya, Teknologi, Dan Pendidikan</i> , 1(8), 1495-1514. https://doi.org/10.54443/sibatik.v1i8.198	1507-1508	31, 41, 95	✓	
29.	Nurkhasanah, S., & Mahmud. (2022). Pengaruh Persepsian Harga Dan Promosi Terhadap Minat Beli Ulang Online Yang	10-12	31, 41, 95		

	Dimediasi Oleh Kepuasan Konsumen (Studi Pada ShopeeFood). <i>JMDB Jurnal Manajemen Dan Dinamika Bisnis</i> , 1(2), 1-16.				
30.	Prasetyo, A., & Suryamugraha, A. (2023). Pengaruh Electronic Word of Mouth Dan Kesadaran Merek (Brand Awareness) Terhadap Minat Beli Ulang Di Kl Coffee Bandar Lampung. <i>Seminar Nasional Hasil Penelitian Dan Pengabdian Masyarakat 2023 Page 38 Institut Informatika Dan Bisnis Darmajaya</i> , 2016, 38-46.	40	16	✓	
31.	Pratama Yudya Putra, A., Layla Zhafira Hilwana, A., Fadhli Al Multazim, M., Zhafran Hafiz, M., & Sarah Maesaroh, syti. (2023). Pengaruh Siaran Langsung Dan Konten Promosi Terhadap Minat Beli Mahasiswa Bisnis Digital UPI Di TikTok Shop. <i>Jimek: Jurnal Ilmiah Mahasiswa Ekonomi</i> , 6(1), 1-21. http://ojs.unik-kediri.ac.id/index.php/jimek	18	5	✓	
32.	Prawita, D., Lukitaningsih, A., & Welsa, H. (2020). ANALISIS PRICE DISCOUNT DAN PERCEIVED USEFULNESS TERHADAP MINAT PEMBELIAN ULANG MENGGUNAKAN FINTECH MELALUI INTERVENING CUSTOMERS SATISFACTION (Studi Kasus Pada Pengguna Aplikasi Gopay di Kota Yogyakarta). <i>Upajiw Dewantara</i> , 4(2), 147-160. https://doi.org/10.26460/mmud.v4i2.8796	149	41	✓	
33.	Rahmawaty, I., Sa'adah, L., & Musyafaah, L. (2023). Pengaruh Live Streaming Selling, Review Product, Dan Discount Terhadap Minat Beli Konsumen Pada E-Commerce Shopee. <i>Jurnal Riset Entrepreneurship</i> , 6(2), 80. https://doi.org/10.30587/jre.v6i2.5956	81	37	✓	
34.	Resti, D., & Soesanto, H. (2016). Pengaruh Persepsi Harga, Kualitas Pelayanan Melalui Kepuasan Pelanggan Terhadap Minat Beli Ulang pada Rumah	1	14, 50	✓	

	Kecantikan Safira di Pati. <i>Diponegoro Journal of Management</i> , 5(1), 1–12.				
35.	Rivai, A. R., & Wahyudi, T. A. (2017). Pengaruh Persepsi Kualitas, Citra Merek, Persepsi Harga terhadap Loyalitas Pelanggan dengan Kepercayaan dan Kepuasan Pelanggan sebagai Variabel Mediasi. <i>Jurnal Bisnis Dan Komunikasi</i> , 4(1), 29–37. https://doi.org/10.36226/jrmb.v4i2.271	32	25	✓	
36.	Rizkina, F. (2022). <i>Pengaruh Kualitas Produk Dan Kualitas Pelayanan Syariah Terhadap Minat Beli Ulang Yang Di Mediasi Oleh Kepuasan Konsumen Pada Toko Nxr Phone</i> . Masters thesis, UIN Ar-Raniry. https://repository.ar-raniry.ac.id/id/eprint/22934/1/FikaRizkina%2C180602005%2CFEBI%2CES%2C085270421226.pdf	152	30, 93	✓	
37.	Rizky, S. N., Sarah, S., & Wijaya, F. (2024). <i>Pengaruh Flash Sale , Gratis Ongkos Kirim , dan Live Streaming terhadap Impulsive Buying pada pengguna Shopee</i> . 5(1).	6	18	✓	
38.	Salsabila, C., Umbara, T., & Setyorini, R. (2022). Pengaruh Kepuasan Pelanggan Terhadap Minat Beli Ulang Produk Somethinc. <i>Publik: Jurnal Manajemen Sumber Daya Manusia, Administrasi Dan Pelayanan Publik</i> , 9(4), 668–679. https://doi.org/10.37606/publik.v9i4.405	677	29, 39, 92	✓	
39.	Saputra, G. G., & Fadhillah, F. (2020). Pengaruh Live Streaming Shopping Instagram Terhadap Kepercayaan Konsumen Online dan Dampaknya pada Keputusan Pembelian. <i>Ekonomi, Keuangan, Investasi Dan Syariah (EKUITAS)</i> , 4(2), 442-.	444	18	✓	
40.	Sarah, & Sobari, N. (2022). The effect of live streaming on purchase intention of e-commerce customers. <i>The 6th International Conference on Family Business and Entrepreneurship</i> , 283–290.	284	4	✓	
41.	Sidanti, H., & Ditta, A. S. A. (2021). Analisis Perilaku terhadap Minat Pembelian	4-5	15	✓	

	Ulang Konsumen Angkringan di Masa Pandemi Covid-19. <i>Conference on Economic and Business Innovation (CEBI)</i> , 1311–1327. https://jurnal.widyagama.ac.id/index.php/cebi/article/view/189				
42.	Simanungkalit, R., Sinaga, N. A., & Hutagalung, J. (2023). Pengaruh Diskon Dan Pelayanan Terhadap Kepuasan Konsumen Pada Cv. Mitra Cahaya Nauli Pandan. <i>Jurnal Ilmiah Penalaran</i> , 5(1), 1–12. https://ejurnal.provisi.ac.id/index.php/jurnalmahasiswa/article/view/511%0Ahttps://ejurnal.provisi.ac.id/index.php/jurnalmahasiswa/article/download/511/420	10-11	32, 36, 88	✓	
43.	Soleha, F., Risal, M., & Wahyuningtyas, N. (2024). pengaruh live streaming, online customer review, cashback promotion dan discount flash sale terhadap minat beli produk shopee (studi kasus pada pengguna shopee di Kota Malang). <i>Jurnal Riset Manajemen</i> , 13(01), 510–518.	635	90	✓	
44.	Sugiyono. (2013). <i>Metode Penelitian Kuantitatif, Kualitatif, dan Tindakan</i> . Bandung : Alfabeta.	39, 63, 92, 93, 137, 142, 243	35, 43, 44, 45, 46, 47, 51,	✓	
45.	Sundari, W. S., & Wahyuningtyas, Y. F. (2023). DAN KEMUDAHAN PEMBAYARAN TERHADAP The Effect Of Price Discounts , Free Shipping And Ease Of Payment On. <i>Jurnal Tambora E-ISSN:</i> , 7(3), 1–9.	7	32, 88	✓	
46.	Syahputri, A. Z., Fallenia, F. Della, & Syafitri, R. (2023). Kerangka berfikir penelitian kuantitatif. <i>Tarbiyah: Jurnal Ilmu Pendidikan Dan Pengajaran</i> , 2(1), 160–166.	161	34	✓	
47.	Tejasari, R. H., Sutikno, B., & Chasanah, U. (2017). <i>Analisis Pengaruh Citra Merk, Kualitas Produk, Diskon Dan Lokasi Terhadap Niat Membeli Ulang Pakaian Di Toko Pakaian “Rahayu”</i> http://eprint.stieww.ac.id/id/eprint/447%0Ahttp://eprint.stieww.ac.id/447/1/151102791%0ARATIH%0AHEL%0ATEJASARI.pdf	51-52	7	✓	
48.	Tjiptono, F. (2016). <i>Strategi Pemasaran</i> (4th	166	21		

	ed.). Andi.				
	Utami, S. H., & Aini, Y. (2020). Pengaruh Price Discount dan Bonus Pack Terhadap Keputusan Pembelian pada Pelanggan Alfamart Kota Tengah Kecamatan Kepenuhan. <i>Jurnal Ilmiah Manajemen Dan Bisnis</i> , 2(1), 120.	122	23, 48	✓	
49.	Wingsati W E, & Prihandono D. (2017). Pengaruh Penanganan Kegagalan Layanan, Kepercayaan, Dan Gaya Hidup Terhadap Minat Pembelian Ulang Melalui Kepuasan Konsumen. <i>Management Analysis Journal</i> , 6(2), 195-205. http://maj.unnes.ac.id	197	4	✓	
50.	Yulianti, N. M. D. R., Suprpti, N. W. S., & Yasa, N. N. K. (2014). Pengaruh Citra Toko Terhadap Kepuasan Pelanggan Dan Niat Beli Ulang Pada Circle K Di Kota Denpasar. <i>Jurnal Manajemen, Strategi Bisnis Dan Kewirausahaan</i> , 8(1), 36-44.	36	3	✓	
51.	Yusuf, J. C., & Prayogo, R. (2021). Pengaruh Kepuasan Konsumen Terhadap Minat Beli Ulang di Traveloka. <i>Jurnal Petra</i> , 9(1), 1-11. www.liputan6.com ,	8	29, 39, 92	✓	

Catatan Dosen Pembimbing

Layak / Tidak Layak untuk diuji (coret yang tidak perlu)

Madiun, Agustus 2024
Dosen Pembimbing

Dr. Apriyanti, S.E., M.M.
NIDN. 0704047305

RIWAYAT HIDUP



Shinta Dwi Hartati, lahir di Kuningan pada tanggal 13 Maret 2001, merupakan anak kedua dari dua bersaudara, dari pasangan Bapak Tatang Somantri dan Ibu Jumyati. Peneliti menempuh Pendidikan dasar hingga menengah di Kabupaten Magetan. Tamat dari SDN Pandeyan 1 pada tahun 2013, melanjutkan ke SMPN 1 Maospati dan tamat pada tahun 2016, lalu menempuh Pendidikan menengah atas di SMAN 1 Maospati dan tamat pada tahun 2019. Pada tahun 2020 peneliti terdaftar sebagai Mahasiswa di Universitas PGRI Madiun Fakultas Ekonomi dan Bisnis Jurusan Manajemen.

Dengan segala usaha dan dukungan dari orang-orang terdekat, peneliti mampu menyelesaikan skripsi ini. Semoga penelitian skripsi ini dapat memberikan manfaat bagi dunia pendidikan.